



Precast Concrete Step Product Information

1 Tread 7" Rise



The Century step is the most durable steel/fiber reinforced concrete step that is easy to install. Add the aluminum handrail and you will have a safe and attractive entrance to your home or business.

Product Specifications:

- 7" Riser Height
- Weight approx. 100 lbs. per tread (step)
- Steel & Fiber Reinforced Concrete
- No Rotting or UV Degradation
- No Assembly Required
- Easily Installed
- Set In Place & Level
- Aluminum Handrail Available
- 7"H x 48"W x 12"D

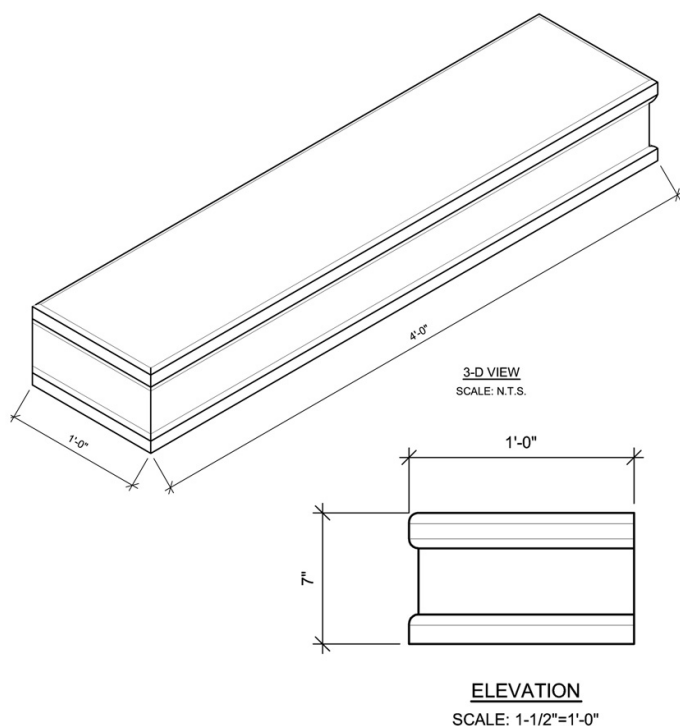

Unit #10017

